

PUBLICATION P12.206

ISSUE: 4

If this document is printed in hardcopy, it is for information use only and therefore is not subject to updating controls. Always refer to viewer for latest issue.

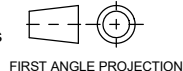

THIS DRAWING IS CONFIDENTIAL AND IS SUPPLIED ON THE EXPRESS CONDITION THAT IT SHALL NOT BE LOANED OR COPIED OR DISCLOSED TO ANY OTHER PERSON OR USED FOR ANY OTHER PURPOSE WITHOUT THE WRITTEN CONSENT OF AP RACING LTD.



© AP Racing Ltd. 2004

AP Racing
Wheler Road
Coventry
CV3 4LB

Tel: +44 024 7663 9595 e-mail: sales@ap racing.co.uk
Fax: +44 024 7663 9559 Web site: HTTP://www.ap racing.com

VW GOLF MK5 FRONT KIT NUMBER CP5570-1015		
Ref	Description	QTY
1	Caliper Right Hand	1
	Caliper Left Hand	1
2	Disc Right Hand	1
	Disc Left Hand	1
3	Pad Set	1
4	Mounting Bracket	2
5	Mounting Bell	2
6	Disc Mtg Bolt	24
7	Washer	48
8	Nut	24
9	OE Bracket Mtg Bolt	N/A
10	0.5mm Washer/Shim	12
11	Caliper Mtg Bolt	4
12	Washer	4
13	Banjo Bolt	2
14	Gasket	4
15	Hose kit	1
16	Nylon Armour	2
17	Pad Retainer Pin	4
18	Anti-Rattle Clip	2
19	Pad Retainer Bolt	4
20	Blanking Harness	2

Tightening Torques	
Part Ref #	Torque
Bolt Ref 9	68NM
Bolt Ref 11	58NM
Bolt/Nut Ref 6/8	14NM
Banjo Bolt Ref 13	25NM
Caliper Bleed Screw	17NM
Pad Retainer Bolt Ref 19	19NM

BRAKE DISC WEAR	
NEW	MIN WORN
28.00mm	27.00mm

Comments
Check caliper is central over disc, Use 0.5mm shims (Part ref 10) to adjust if required.
This brake kit will not allow the use of the brake pad wear sensors found on OE pads.

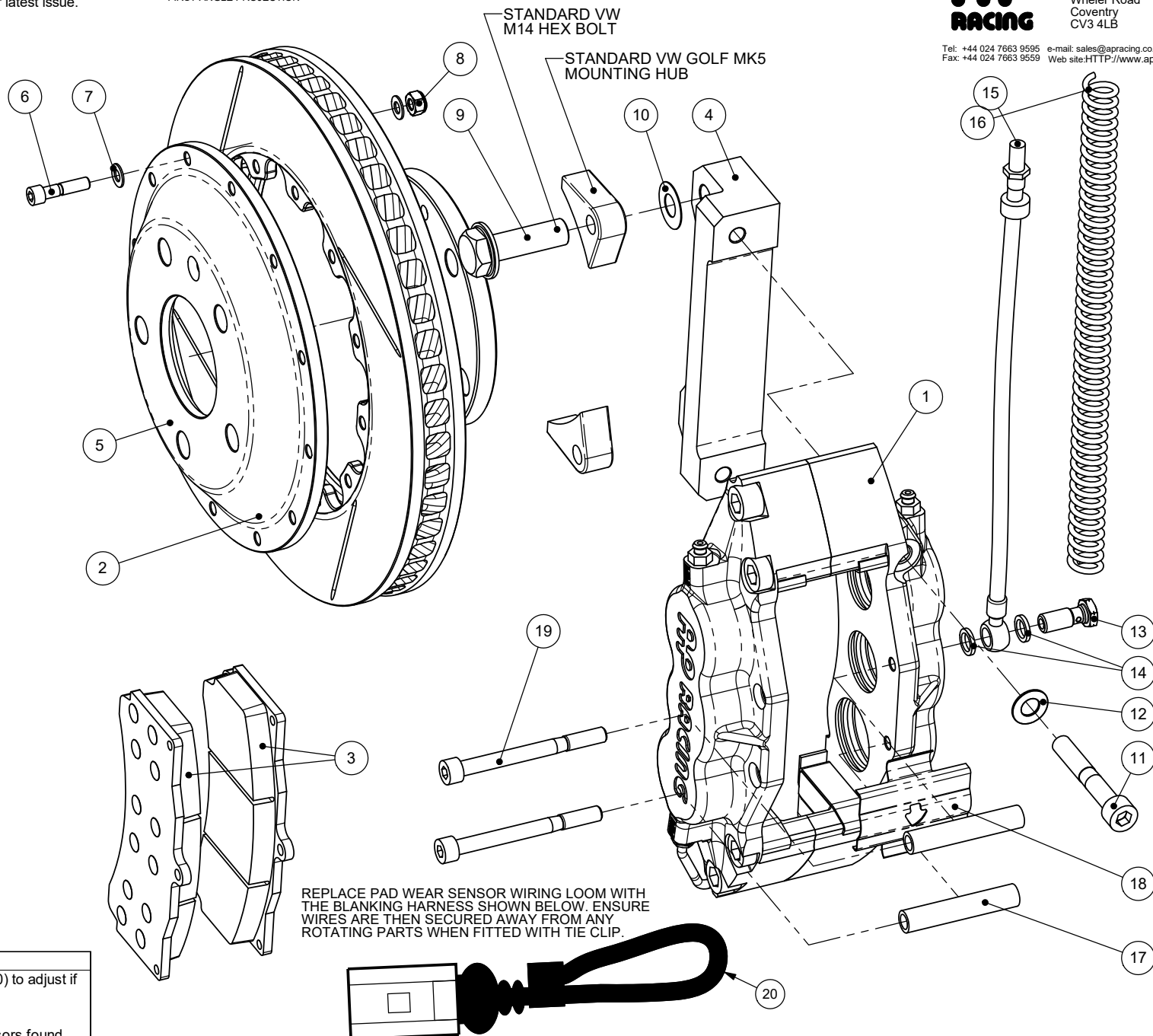

PLEASE RETAIN THIS SHEET FOR FUTURE REFERENCE

DRAWN : P.Mercier