

# A1 INSTALLATION DRAWING

IF THIS DOCUMENT IS PRINTED IN HARDCOPY, IT IS FOR INFORMATION USE ONLY AND THEREFORE IS NOT SUBJECT TO UPDATING CONTROLS. ALWAYS REFER TO SOLIDWORKS VIEWER FOR LATEST ISSUE



THIS DRAWING IS CONFIDENTIAL AND IS SUPPLIED ON THE EXPRESS CONDITION THAT IT SHALL NOT BE LOANED OR COPIED OR DISCLOSED TO ANY OTHER PERSON OR USED FOR ANY OTHER PURPOSE WITHOUT THE WRITTEN CONSENT OF AP RACING LTD.



AP Racing  
Wheler Road  
Coventry  
CV3 4LB

Tel: +44 (0) 24 7663 9595  
Fax: +44 (0) 24 7663 9559  
e-mail: [engineering@apracings.co.uk](mailto:engineering@apracings.co.uk)  
Web site: <http://www.apracings.com>

© AP Racing Ltd. 2005

**DISC PART NUMBERS:**

CP3047-372 RH AS SHOWN  
CP3047-373 LH OPPOSITE

THIS IS A 48 VANES DISC OF MASS 4.99Kg

THIS DISC WAS DESIGNED TO WORK WITH A D51.56 DEPTH PAD.

FOR DISC MOUNTING TECHNIQUES, BEDDING PROCEDURE AND DISC COOLING RECOMMENDATIONS SEE AP RACING BRAKE DISC CATALOGUE.

## DISC INSTALLATION

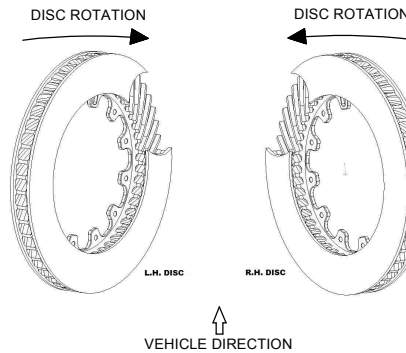

12 HOLES  $\phi 6.425 \pm 0.025$   
EQUI-SPACED ON A  $203.2 \text{ PC}\phi$

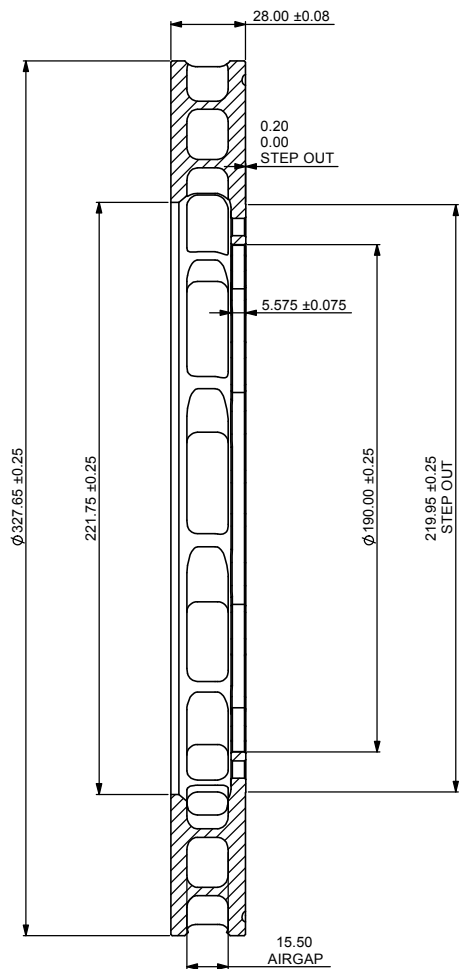
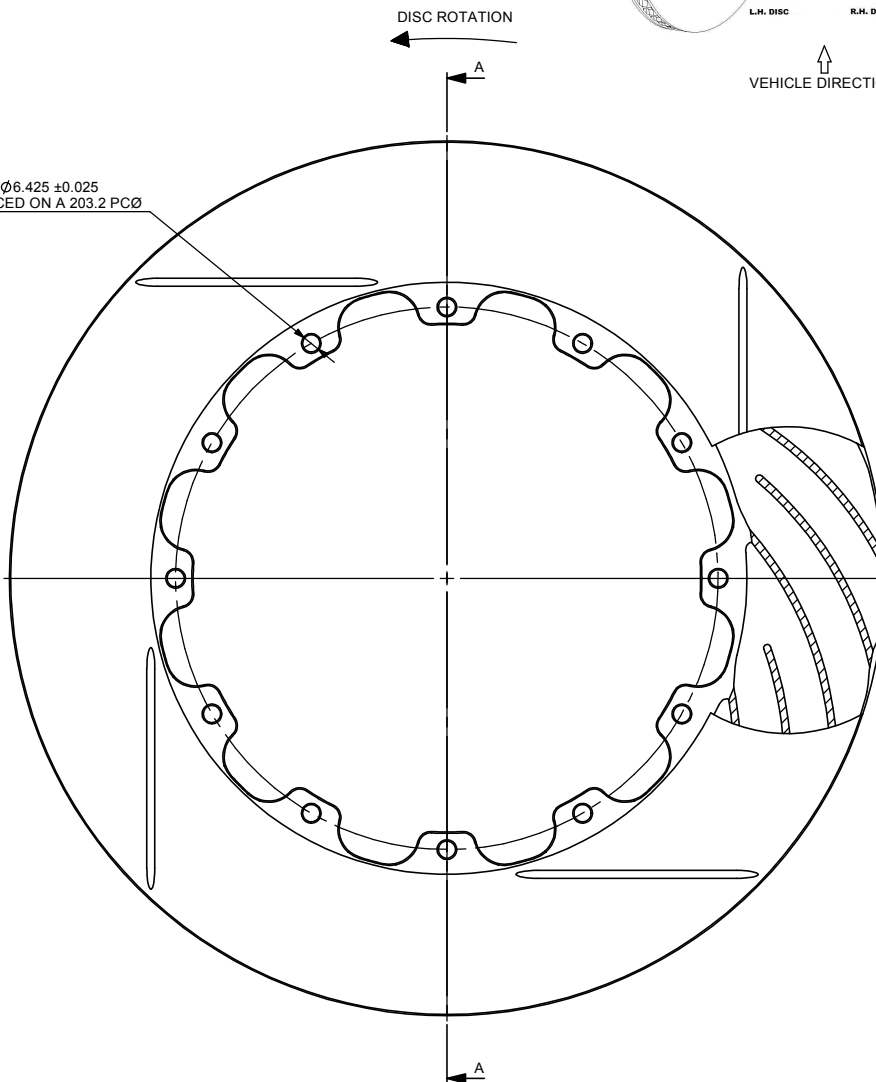

SECTION A-A

Issue No.	Date & No.	Alterations		Zone	Initials
		Particulars	#		
1	02/03/06 B4494	FIRST ISSUE			DRA
2	17/05/06 B4460	CONVERTED TO TWIN TURNING, 0.20/0.00 STEP ADDED			SAT

SCALE 1:1		SHEET 1 OF 1	
DRAWN	D.ARROWSMITH		
APPROVED			
DERIVED FROM			
TITLE			
$\phi 327.65 \times 28.0$			
VENTILATED DISC			
DRG NO.	CP3047-372/373G4		