

A1 INSTALLATION DRAWING

IF THIS DOCUMENT IS PRINTED IN HARDCOPY, IT IS FOR INFORMATION USE ONLY AND THEREFORE IS NOT SUBJECT TO UPDATING CONTROLS. ALWAYS REFER TO SOLIDWORKS VIEWER FOR LATEST ISSUE



FIRST ANGLE PROJECTION

THIS DRAWING IS CONFIDENTIAL AND IS SUPPLIED ON THE EXPRESS CONDITION THAT IT SHALL NOT BE LOANED OR COPIED OR DISCLOSED TO ANY OTHER PERSON OR USED FOR ANY OTHER PURPOSE WITHOUT THE WRITTEN CONSENT OF AP RACING LTD.



© AP Racing Ltd. 2004

AP Racing
Wheler Road
Coventry
CV3 4LB

Tel: +44 (0) 24 7663 9595
Fax: +44 (0) 24 7663 9599
e-mail: engineering@apracings.co.uk
Web site: http://www.apracings.com

Issue No.	Alterations		Zone	Initials
	Date & No.	Particulars		
1	27/10/2004	FIRST ISSUE	#	CDA
2	31/05/2004	SEVERAL NOTES WERE UPDATED.	#	CDA

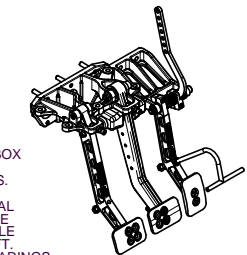
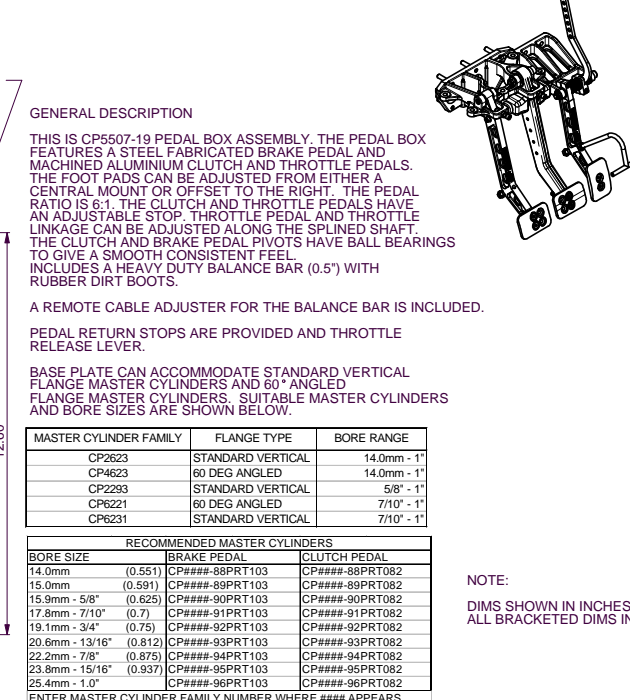
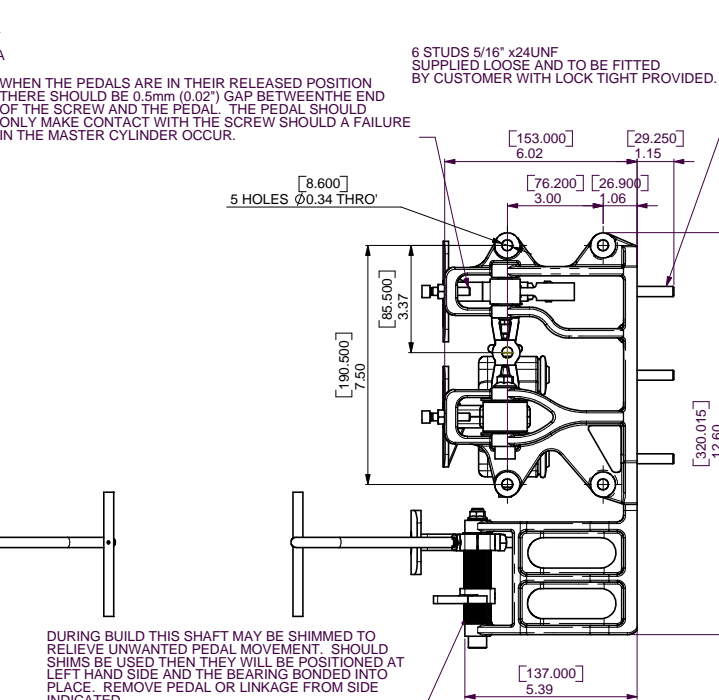
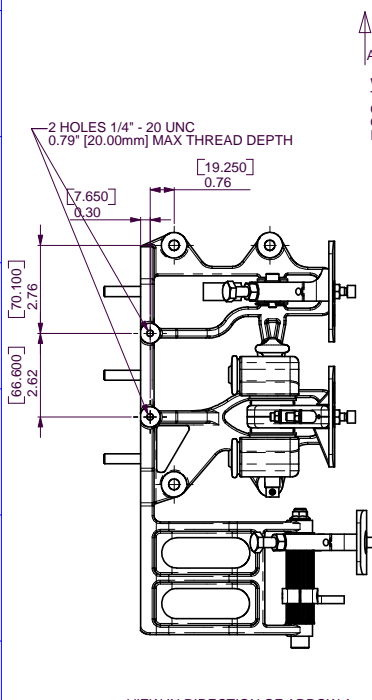
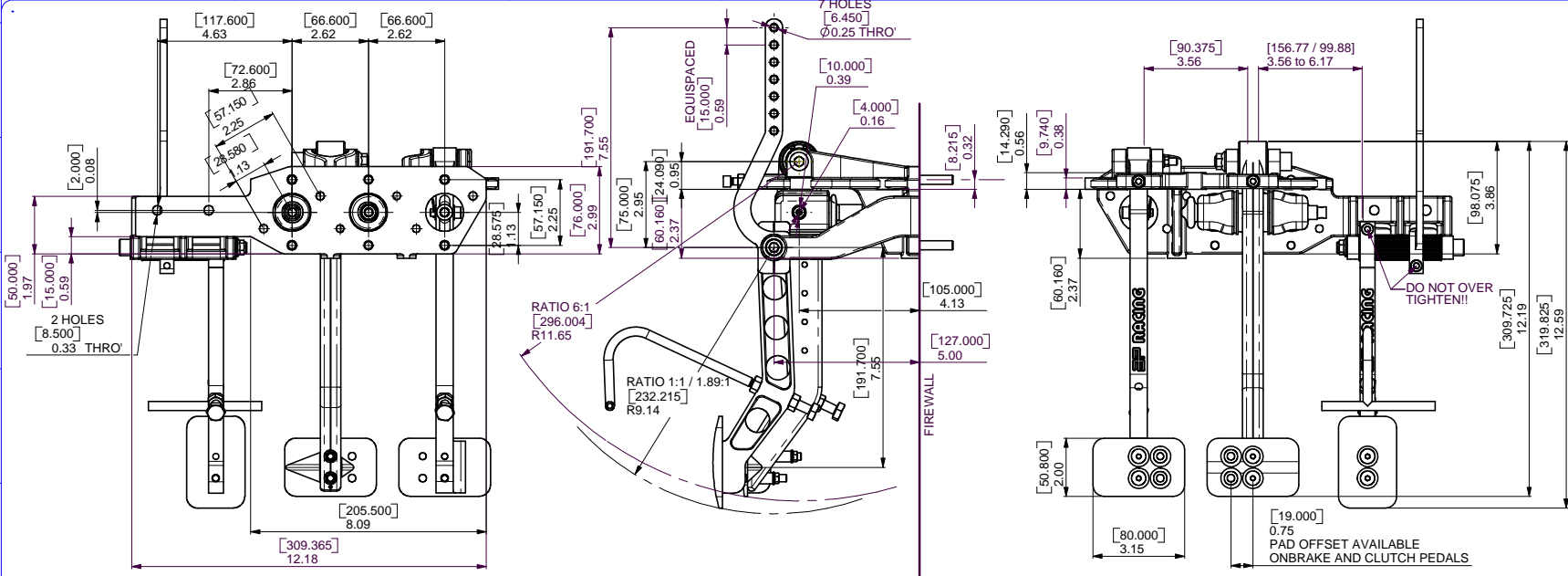

GENERAL DESCRIPTION

THIS IS CP5507-19 PEDAL BOX ASSEMBLY. THE PEDAL BOX FEATURES A STEEL FABRICATED BRAKE PEDAL AND MACHINED ALUMINIUM CLUTCH AND THROTTLE PEDALS. THE FOOT PADS CAN BE ADJUSTED FROM EITHER A CENTRAL MOUNT OR OFFSET TO THE RIGHT. THE PEDAL RATIO IS 6:1. THE CLUTCH AND THROTTLE PEDALS HAVE AN ADJUSTABLE STOP. THROTTLE PEDAL AND THROTTLE LINKAGE CAN BE ADJUSTED ALONG THE SPLINED SHAFT. THE CLUTCH AND BRAKE PEDAL PIVOTS HAVE BALL BEARINGS TO GIVE A SMOOTH CONSISTENT FEEL. INCLUDES A HEAVY DUTY BALANCE BAR (0.5\") WITH RUBBER DIRT BOOTS.

A REMOTE CABLE ADJUSTER FOR THE BALANCE BAR IS INCLUDED.

PEDAL RETURN STOPS ARE PROVIDED AND THROTTLE RELEASE LEVER.

BASE PLATE CAN ACCOMMODATE STANDARD VERTICAL FLANGE MASTER CYLINDERS AND 60° ANGLED FLANGE MASTER CYLINDERS. SUITABLE MASTER CYLINDERS AND BORE SIZES ARE SHOWN BELOW.

MASTER CYLINDER FAMILY	FLANGE TYPE	BORE RANGE
CP2623	STANDARD VERTICAL	14.0mm - 1\"
CP4623	60 DEG ANGLED	14.0mm - 1\"
CP2293	STANDARD VERTICAL	5/8\" - 1\"
CP6221	60 DEG ANGLED	7/10\" - 1\"
CP6231	STANDARD VERTICAL	7/10\" - 1\"

RECOMMENDED MASTER CYLINDERS		
BORE SIZE	BRAKE PEDAL	CLUTCH PEDAL
14.0mm - (0.551)	CP####-88PRT103	CP####-88PRT082
15.0mm - (0.591)	CP####-89PRT103	CP####-89PRT082
15.9mm - 5/8\" (0.625)	CP####-90PRT103	CP####-90PRT082
17.8mm - 7/10\" (0.7)	CP####-91PRT103	CP####-91PRT082
19.1mm - 3/4\" (0.75)	CP####-92PRT103	CP####-92PRT082
20.6mm - 13/16\" (0.812)	CP####-93PRT103	CP####-93PRT082
22.2mm - 7/8\" (0.875)	CP####-94PRT103	CP####-94PRT082
23.8mm - 15/16\" (0.937)	CP####-95PRT103	CP####-95PRT082
25.4mm - 1.0\"	CP####-96PRT103	CP####-96PRT082

ENTER MASTER CYLINDER FAMILY NUMBER WHERE #### APPEARS.

NOTE:
DIMS SHOWN IN INCHES
ALL BRACKETED DIMS IN MM

SCALE 1:2	SHEET 1 OF 2
DRAWN	CHRIS ARROWSMITH
APPROVED	
DERIVED FROM	
TITLE	
UNDERSLUNG PUSH TYPE PEDAL BOX, 3 PEDAL ASSEMBLY	
DRG NO.	cp5507-19cd

A1 INSTALLATION DRAWING

IF THIS DOCUMENT IS PRINTED IN HARD COPY, IT IS FOR INFORMATION USE ONLY AND THEREFORE IS NOT SUBJECT TO UPDATING CONTROLS. ALWAYS REFER TO SOLIDWORKS VIEWER FOR LATEST ISSUE



THIS DRAWING IS CONFIDENTIAL AND IS SUPPLIED ON THE EXPRESS CONDITION THAT IT SHALL NOT BE LOANED OR COPIED OR DISCLOSED TO ANY OTHER PERSON OR USED FOR ANY OTHER PURPOSE WITHOUT THE WRITTEN CONSENT OF AP RACING LTD.



© AP Racing Ltd. 2004

AP Racing
Wheeler Road
Coventry
CV3 4LB

Tel: +44 (0) 24 7663 9595
Fax: +44 (0) 24 7663 9599
e-mail: engineering@apracings.co.uk
Web site: http://www.apracings.com

Issue No.	Alterations		Zone	Initials
	Date & No.	Particulars		
		SEE SHEET 1 FOR ISSUE INFO		

INCLUDES SPRING WASHERS AND LOCK NUTS TO HOLD MASTER CYLINDERS TO THE PEDAL BOX.

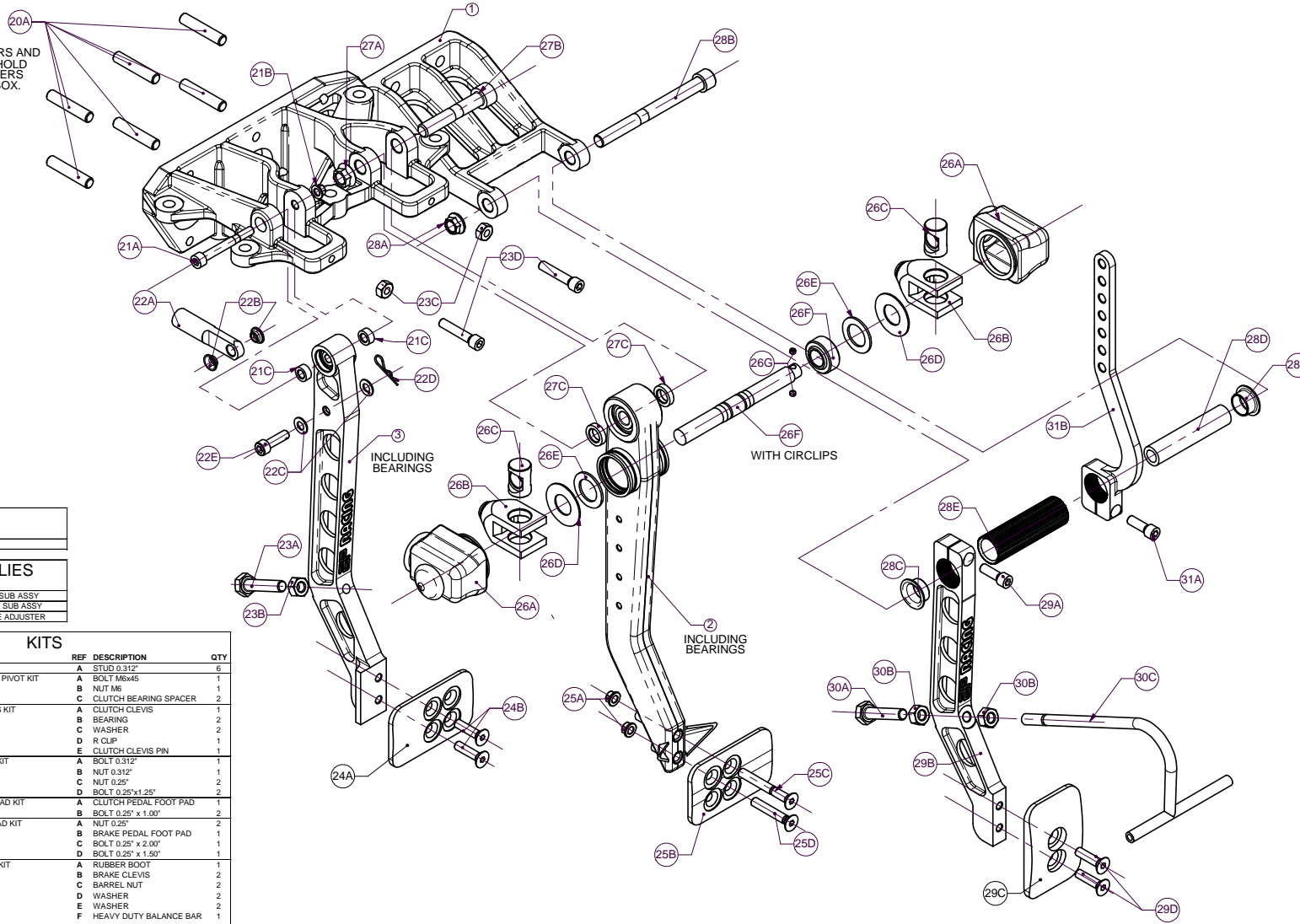

PARTS	
REF	Pt. No. DESCRIPTION
1	CP5507-191 BASE PLATE

SUB ASSEMBLIES	
REF	Pt. No. DESCRIPTION
2	CP5507-197 BRAKE PEDAL SUB ASSY
3	CP5507-198 CLUTCH PEDAL SUB ASSY
4	CP2906-18 REMOTE CABLE ADJUSTER

KITS					
REF	Pt. No.	DESCRIPTION	QTY		
20	CP5507-20	STUD KIT	6		
21	CP5507-21	A BOLT M6x45	1		
		B NUT M6	1		
		C CLUTCH BEARING SPACER	2		
22	CP5507-22	A CLUTCH CLEVIS	1		
		B BEARING	2		
		C WASHER	2		
		D R CLIP	1		
		E CLUTCH CLEVIS PIN	1		
23	CP5507-23	A BOLT 0.312"	1		
		B NUT 0.312"	1		
		C NUT 0.25"	2		
		D BOLT 0.25" x 1.25"	2		
24	CP5507-24	A CLUTCH PEDAL FOOT PAD	1		
		B BOLT 0.25" x 1.00"	2		
		C BOLT 0.25" x 2.00"	1		
		D BOLT 0.25" x 1.50"	1		
25	CP5507-25	A NUT 0.25"	2		
		B BRAKE PEDAL FOOT PAD	1		
		C BOLT 0.25" x 2.00"	1		
		D BOLT 0.25" x 1.50"	1		
		E RUBBER BOOT	1		
		F BRAKE CLEVIS	2		
		G BARREL NUT	2		
		H WASHER	2		
26	CP5507-26	A RUBBER BOOT	1		
		B BRAKE CLEVIS	2		
		C BARREL NUT	2		
		D WASHER	2		
		E WASHER	2		
27	CP5507-27	F HEAVY DUTY BALANCE BAR	1		
		G GRUB SCREW 0.16"	2		
		H RUBBER BOOT	1		
		A NUT M10	1		
		B BOLT M10 x 57	1		
		C BRAKE BEARING SPACER	2		
		28	CP5507-28	A NUT 0.38"	1
				B BOLT 0.38" x 4.00"	1
C BEARING	2				
D SLEEVE	1				
E SPLINED SHAFT	1				
29	CP5507-29	A BOLT 0.25" x 0.75"	1		
		B THROTTLE PEDAL	1		
		C THROTTLE PEDAL FOOT	1		
		D BOLT 0.25" x 1.00"	2		
30	CP5507-30	A BOLT 0.312"	1		
		B NUT .31UNF	2		
		C THROTTLE RELEASE LEVER	1		
31	CP5507-31	A BOLT 0.25" x 0.75"	1		
		B THROTTLE LINKAGE	1		

SCALE 1:2 SHEET 2 OF 2

DRAWN	CHRIS ARROWSMITH
APPROVED	
DERIVED FROM	

TITLE
UNDERSLUNG PUSH TYPE PEDAL BOX, 3 PEDAL ASSEMBLY

DRG NO. cp5507-19cd