

B1 INSTALLATION DRAWING

IF THIS DOCUMENT IS PRINTED IN HARDCOPY, IT IS FOR INFORMATION USE ONLY AND THEREFORE IS NOT SUBJECT TO UPDATING CONTROLS. ALWAYS REFER TO SOLIDWORKS VIEWER FOR LATEST ISSUE



THIS DRAWING IS CONFIDENTIAL AND IS SUPPLIED ON THE EXPRESS CONDITION THAT IT SHALL NOT BE LOANED OR COPIED OR DISCLOSED TO ANY OTHER PERSON OR USED FOR ANY OTHER PURPOSE WITHOUT THE WRITTEN CONSENT OF AP RACING LTD.

AP Racing
Wheler Road
Coventry
CV3 4LB
Tel: +44 024 7663 9595
Fax: +44 024 7663 9559
e-mail: sales@apracings.co.uk
Web site: HTTP://www.apracings.com

© AP Racing Ltd. 2005

CALIPER SPECIFICATION

BORE SIZE	31.8 x 36.0 x 38.2 (1.25"x1.42"x1.50")
PISTON AREA / PAD	29.5 cm ²
DISC DIA. MAX.	410.00
DISC THICKNESS MAX.	35.56
DISC THICKNESS MIN. (WORN CONDITION)	34.00
WORKING PRESSURE MAX.	SEE DATA SHEET P14.164 (AVAILABLE FROM AP RACING TECHNICAL DEPT.)
HYDRAULIC FEED	M10 x 1.0
DRY WEIGHT (LESS PADS)	6.1 kg
PAD FAMILY	CP8310
EFFECTIVE RADIUS (ON DIA. 410.00 DISC)	171.00
'L' DIMN.	92.50
OFFSET	52.00
'C' DIMN.	
MTG. HOLE CENTRES 'D' DIMN.	210.00
PAD FRICTION MATERIAL	
MIN. THICKNESS	2.50
PAD RETENTION	RETAINER TUBES + M10 BOLTS
TIGHTENING TORQUES	BLEED SCREW : 17Nm HYDRAULIC FEED : 25Nm
CORROSION PROTECTION	FLUID RESISTANT PAINT FINISH - ALUMINIUM BODY BOOT TYPE DIRT SEALS.

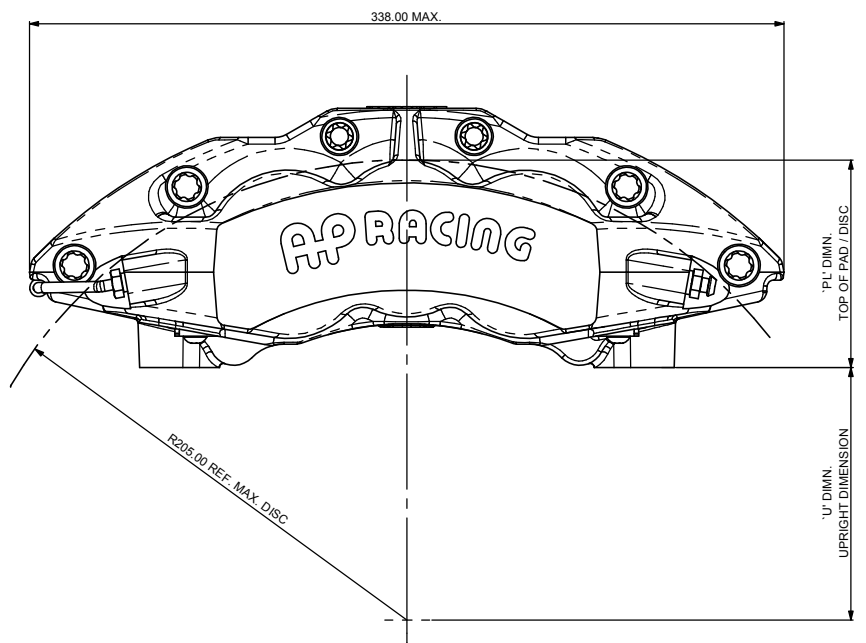
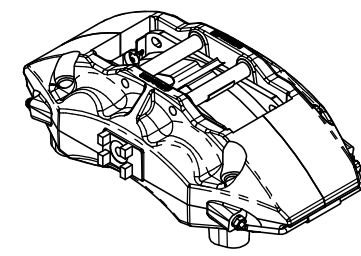
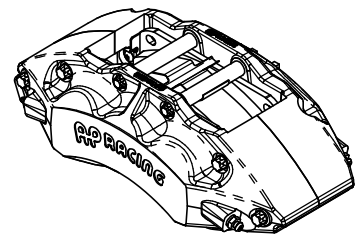

CALIPER POSITIONING CHART

RHT	RIGHT HAND TRAILING (BEHIND AXLE)
LHT	LEFT HAND TRAILING (BEHIND AXLE)
RHL	RIGHT HAND LEADING (IN FRONT OF AXLE)
LHL	LEFT HAND LEADING (IN FRONT OF AXLE)

PART NUMBERING CONVENTION

PART NUMBER	DESCRIPTION
CP8317-2S0	RHT - SIDE FEED - NO ANTI KNOCK BACK SPRING
CP8317-3S0	LHT - SIDE FEED - NO ANTI KNOCK BACK SPRING
CP8317-4S0	RHL - SIDE FEED - NO ANTI KNOCK BACK SPRING
CP8317-5S0	LHL - SIDE FEED - NO ANTI KNOCK BACK SPRING

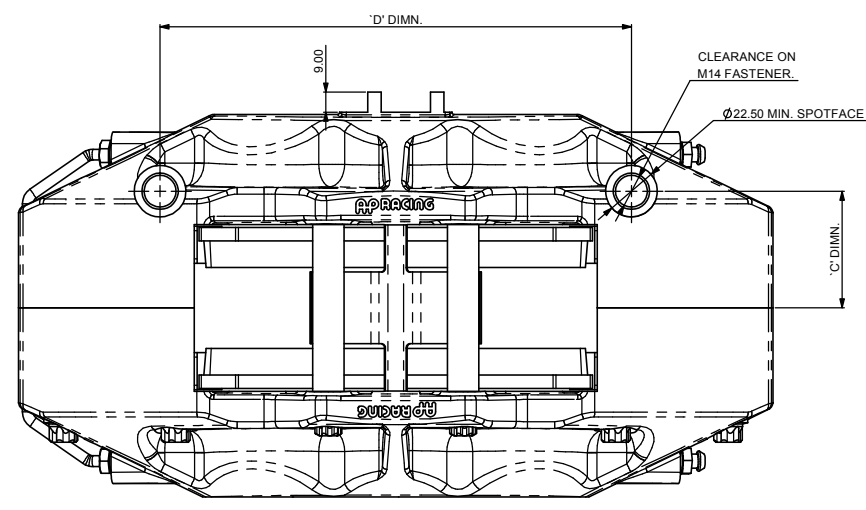
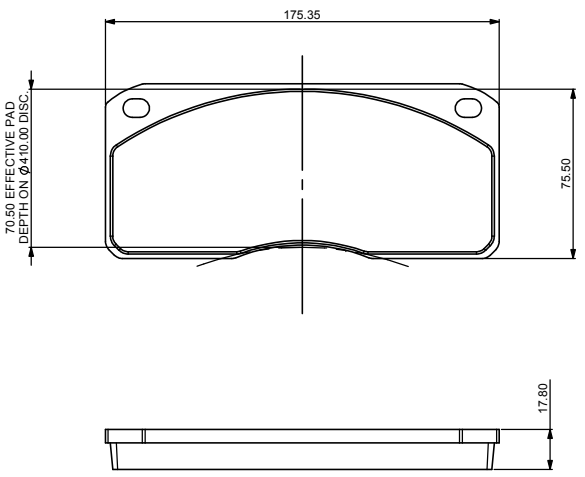
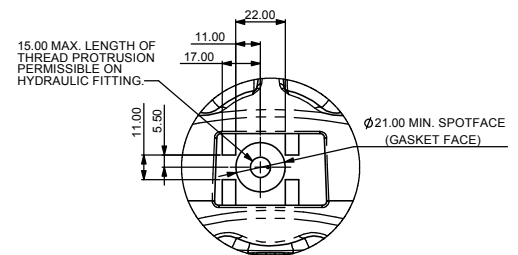

CP8310 PAD FAMILY
PAD AREA (MAX.) - 109.1 cm²

FOR INSTALLED PROFILES SEE SHEET 2

REV	Alterations			Zone	Initials
	Date & No.	Particulars	#		
1	06/07/06 R2044	FIRST ISSUE			JS

SCALE 1:1	SHEET 1 OF 2
DRAWN	Jon Simmonds
APPROVED	
DERIVED FROM	
TITLE	HEAVY DUTY 6 PISTON CALIPER INSTALLATION DRAWING
DRG NO.	CP8317-1CD

