

THIS DRAWING IS CONFIDENTIAL AND IS SUPPLIED ON THE EXPRESS CONDITION THAT IT SHALL NOT BE LOANED OR COPIED OR DISCLOSED TO ANY OTHER PERSON OR USED FOR ANY OTHER PURPOSE WITHOUT THE WRITTEN CONSENT OF AP RACING LTD.



AP Racing
 Wheler Road
 Coventry
 CV3 4LB

Tel: +44 024 7663 9595
 Fax: +44 024 7663 9559

e-mail: sales@apracings.co.uk
 Web site: HTTP://www.apracings.com

© AP Racing Ltd. 2005

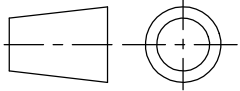

IF THIS DOCUMENT IS PRINTED IN HARDCOPY, IT IS FOR INFORMATION ONLY AND THEREFORE IS NOT SUBJECT TO UPDATING CONTROLS. ALWAYS REFER TO VIEWER FOR LATEST ISSUE.

FIRST ANGLE PROJECTION

INSTRUCTIONS FOR DALLARA BRAKE PEDAL MODIFICATION

STAGE 1:
 PRESS TOP-HAT BUSH (1) OUT OF STANDARD DALLARA BRAKE PEDAL (2)
 ENSURE BRAKE PEDAL IS SUPPORTED CLOSE TO BORE 'X'

STAGE 2:
 CLEAN BORE 'X' OF STANDARD DALLARA BRAKE PEDAL (2) & Ø 'Y' OF AP RACING SUB-ASSY (3) USING A LOCTITE CLEANING SOLVENT & ALLOW TO DRY.

STAGE 3:
 SPRAY BORE 'X' OF STANDARD DALLARA BRAKE PEDAL (2) & Ø 'Y' OF AP RACING SUB-ASSY (3) WITH LOCTITE ACTIVATOR 7471 OR 7649 & ALLOW TO DRY.
 ** CARE MUST BE TAKEN NOT TO SPRAY THE PIVOT BEARINGS 'Z' IN THE PEDAL**

STAGE 4:
 APPLY LOCTITE 648 RETAINING COMPOUND AROUND THE LEADING EDGE OF THE AP RACING SUB-ASSY (3) & IN BORE 'X' OF THE STANDARD DALLARA BRAKE PEDAL (2). FIT AP RACING SUB-ASSY (3) INTO STANDARD DALLARA BRAKE PEDAL (2) USING A ROTATING MOTION TO ENSURE GOOD COVERAGE OF ADHESIVE. **ALLOW TO 24 HOURS TO CURE PRIOR TO USE.**

THE CUSTOMER IS RESPONSIBLE FOR ENSURING THAT THE AP RACING TOP-HAT SUB ASSY IS SECURELY BONDED

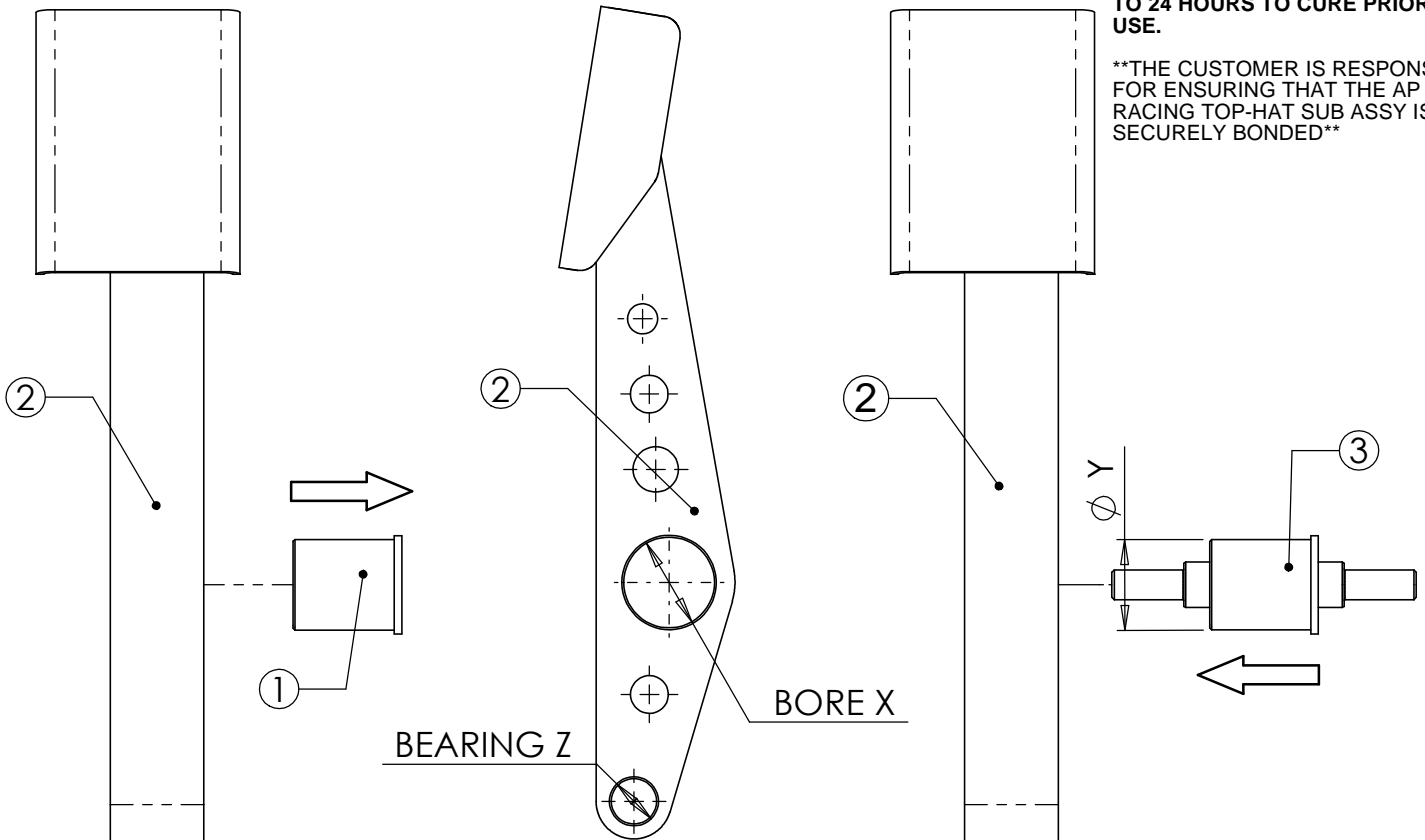

DETAILS FOR FITTING THE PEDAL BOX TO THE CAR

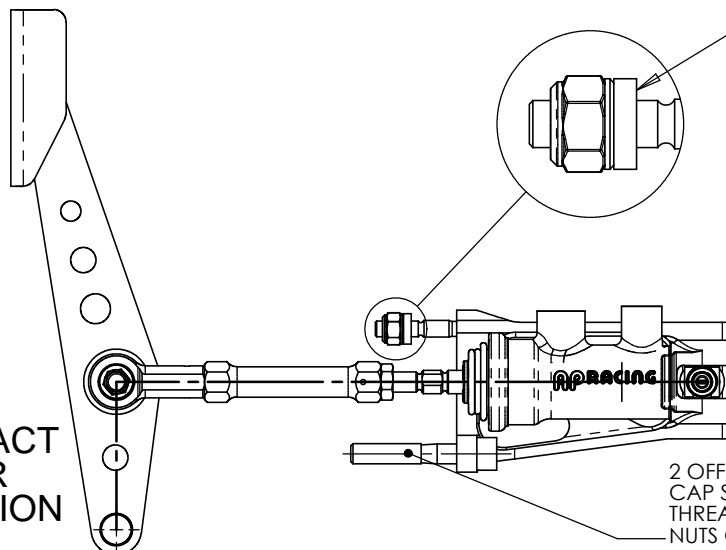

SECURE TOP FIXING POINT USING CP5528-111 CONVEX WASHER, CP5528-112 CONCAVE WASHER & CP2494-117 1/4" UNF PHILIDAS NUT. TIGHTEN TO 17Nm.

2 OFF M8 SOCKET HEAD CAP SCREWS TO BE THREADED INTO CAPTIVE NUTS ON PEDAL BOX

FOR MORE DETAILS CONTACT AP RACING FOR THE INSTALLATION DRAWING.

P14.242
 ISSUE 1