

A4

P16.270

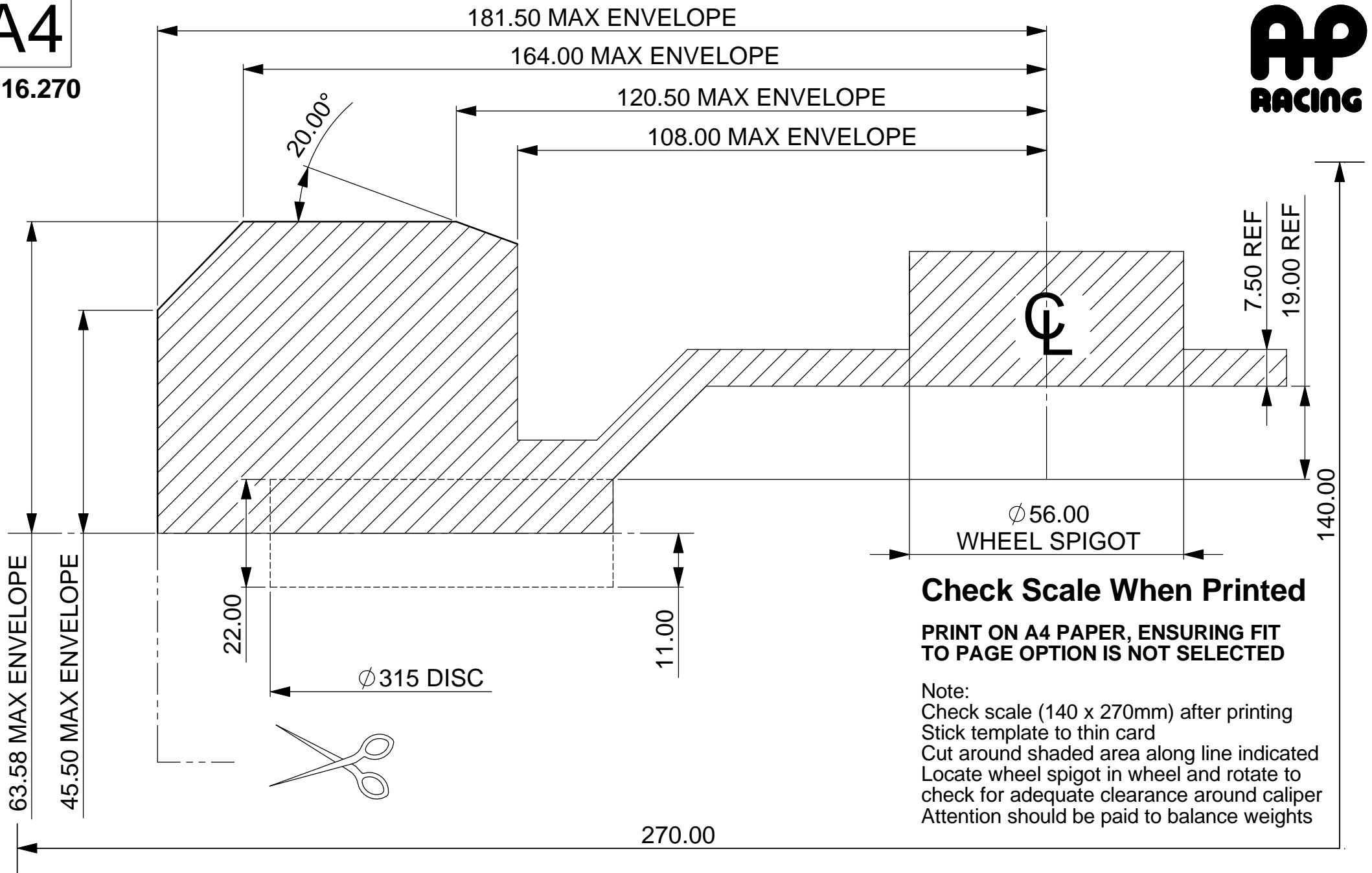

Check Scale When Printed

PRINT ON A4 PAPER, ENSURING FIT TO PAGE OPTION IS NOT SELECTED

Note:

Check scale (140 x 270mm) after printing
 Stick template to thin card
 Cut around shaded area along line indicated
 Locate wheel spigot in wheel and rotate to check for adequate clearance around caliper
 Attention should be paid to balance weights

Cut Around Shaded Profile
MIN. WHEEL CLEARANCE = 4.00mm

AP Racing Ltd.
 Wheler Road
 Coventry
 CV3 4LB

Tel: +44 024 7663 9595
 Fax: +44 024 7663 9559
 web: www.apracing.com
 e-mail: sales@apracing.co.uk

TITLE	INSTALLATION PROFILE
PART NO	CP7645-1001 KIT